

Standard Installation



Flammable



Warning



High Voltage



Hot Surface

TOOLS NEEDED:	
	Waterproof Wire Connectors
	Adjustable Crescent Wrench
	Flat Head Screwdriver
	TORX T27 Tamper Resistant 1/4" Bit
	Mounting Hardware 3/4" Bolt w/ Lockwasher
	Torque Wrench & 3/4" Socket

INSTRUCTIONS PERTAINING TO A RISK OF FIRE, OR INJURY TO PERSONS IMPORTANT SAFETY INSTRUCTIONS

Lighted fixture is HOT!

WARNING - To reduce the risk of FIRE OR INJURY TO PERSONS:

Turn off/unplug and allow to cool before replacing lamp/LED. Fixture gets HOT quickly! Contact only switch/plug when turning on. Do not touch hot lens, guard, or enclosure. Keep fixture away from materials that may burn. Do not operate the luminaire fitting with a missing or damaged shield. Do not touch the source at any time. Use a soft cloth or gloves. Oil from skin may cause damage.

SAVE THESE INSTRUCTIONS

IMPORTANT SAFETY INFORMATION - READ, FOLLOW, AND SAVE ALL SAFETY AND INSTALLATION INSTRUCTIONS

- Product must be installed by a qualified person in a manner consistent with its intended use and in compliance with the National Electrical Code, Canadian Electrical Code, and all Local and Provincial Codes.
- Follow product label information and instructions.
- Qualified Personnel with appropriate personal protective equipment must perform all servicing of this product.
- Before wiring to power supply and during servicing, turn off and lock out power at fuse or circuit breaker before service.
- The use of accessory equipment not recommended by the manufacturer or installed contrary to instructions may cause an unsafe condition. The use of damaged components may cause an unsafe condition and void product warranty.
- Do not block light emanating from product in whole or part, as this may cause an unsafe condition.
- Never operate the fixture with missing or damaged lens. Lens must be cleaned on regular basis.
- Entire fixture may become extremely hot. Do not touch hot lens or fixture body.
- Replace LED assembly only with correct wattage and type of power supply appropriate for LED assembly.
- All gaskets, o-rings and sealing surfaces must be kept clean during installation and service; failure to do this may cause an unsafe condition and void product warranty.

IMPORTANT LISTINGS AND CERTIFICATIONS

- Suitable for wet locations

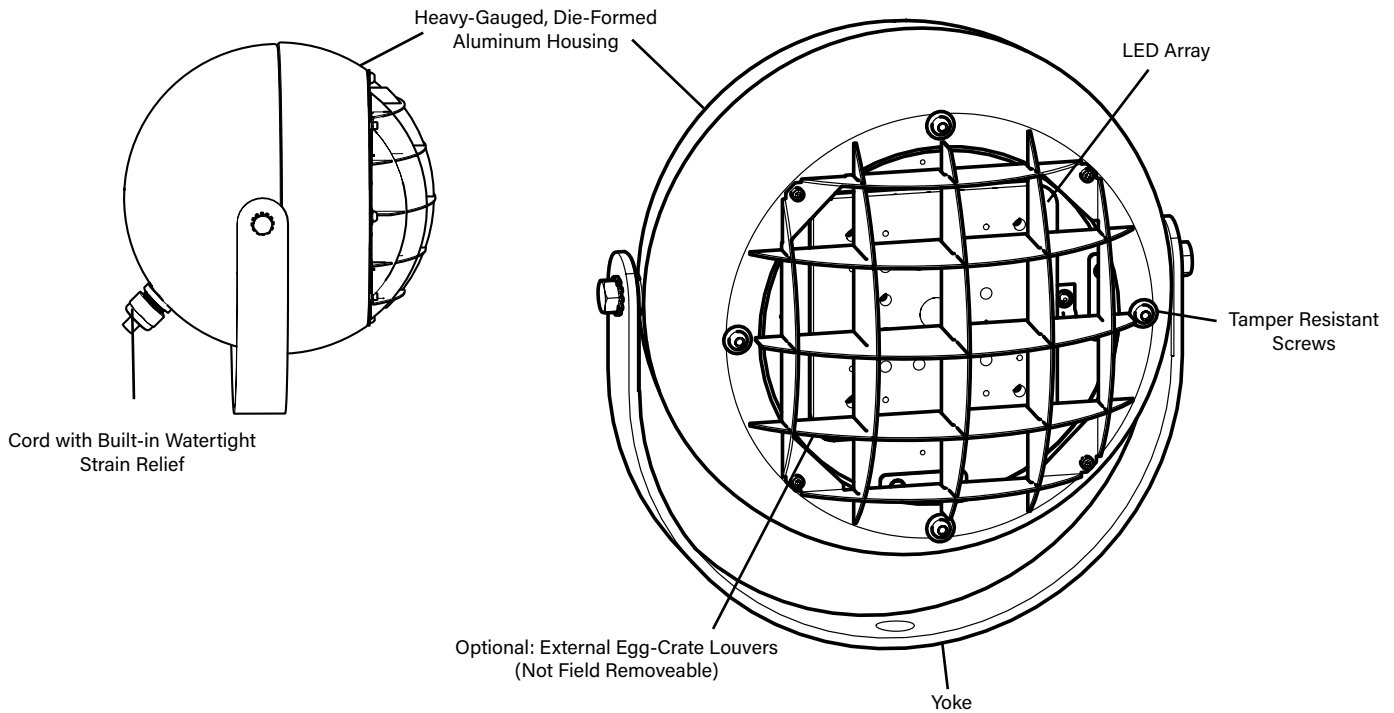

ORION - YOKE MOUNT

IMPORTANT SAFETY INFORMATION - READ, FOLLOW, AND SAVE THESE INSTALLATION INSTRUCTIONS

B-K LIGHTING

40429 Brickyard Drive • Madera, CA 93636 • USA
559.438.5800 • FAX 559.438.5900
www.bklighting.com • info@bklighting.com

RELEASE DATE
06/27/2023

REFERENCE NUMBER
INS-2506-00

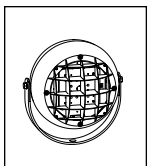

Standard Installation

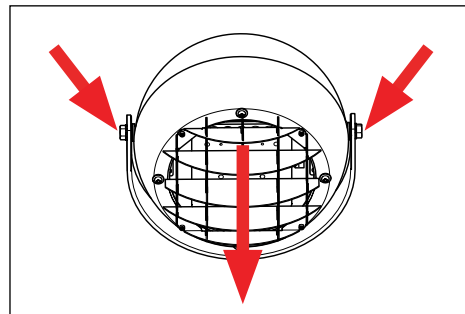
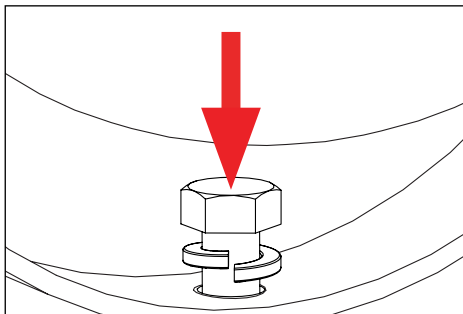
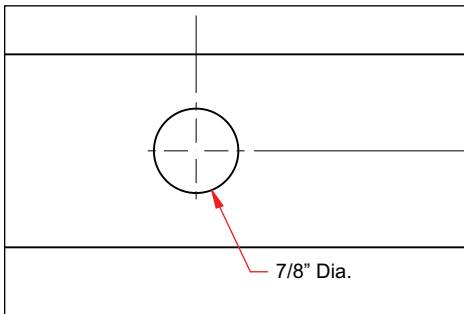

1. Prepare for installation for yoke location. Clearance hole is 7/8" diameter.
2. Line up fixture yoke to mounting location and secure with 3/4"-10 bolt (not included) and locking washer. Using torque wrench, **tighten to 30 ft-lbs** (mounting hardware not included).
3. Adjust aim by slightly loosening two (2) 1/2-13" bolts using a 3/4" socket. Aim fixture to desired position and re-tighten bolts to secure in place. Using torque wrench, **tighten each bolt to 25 ft-lbs**.

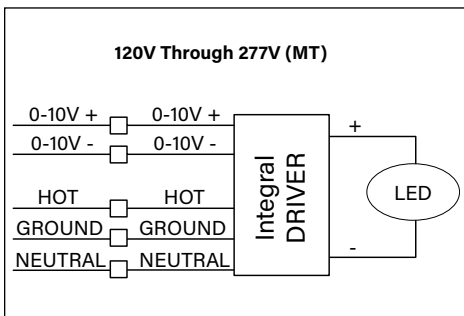

WIRING DIAGRAM

4. Fixture internal wiring (primary and secondary) are factory pre-wired. Fixture is provided with 2ft. leads for installer to make appropriate connections. Make watertight connections using waterproof wire connectors to connect primary wiring per NEC. Be sure to leave enough cord length for aiming the fixture.

**IMPORTANT SAFETY INFORMATION LISTED ON REVERSE
READ, FOLLOW, AND SAVE ALL SAFETY AND INSTALLATION INSTRUCTIONS**

