

Standard Installation



Flammable



Warning



High Voltage



Hot Surface

TOOLS NEEDED:	
	1/8" Allen Wrench
	Waterproof Wire Connectors
	Level
	Phillips Screwdriver
	Torque Wrench

INSTRUCTIONS PERTAINING TO A RISK OF FIRE, OR INJURY TO PERSONS IMPORTANT SAFETY INSTRUCTIONS

Lighted fixture is HOT!

WARNING - To reduce the risk of FIRE OR INJURY TO PERSONS:

Turn off/unplug and allow to cool before replacing lamp/LED. Fixture gets HOT quickly! Contact only switch/plug when turning on. Do not touch hot lens, guard, or enclosure. Keep fixture away from materials that may burn. Do not operate the luminaire fitting with a missing or damaged shield. Do not touch the source at any time. Use a soft cloth or gloves. Oil from skin may cause damage.

SAVE THESE INSTRUCTIONS

IMPORTANT SAFETY INFORMATION - READ, FOLLOW, AND SAVE ALL SAFETY AND INSTALLATION INSTRUCTIONS

- Product must be installed by a qualified person in a manner consistent with its intended use and in compliance with the National Electrical Code, Canadian Electrical Code, and all Local and Provincial Codes.
- Follow product label information and instructions.
- Qualified Personnel with appropriate personal protective equipment must perform all servicing of this product.
- Before wiring to power supply and during servicing, turn off and lock out power at fuse or circuit breaker before service.
- The use of accessory equipment not recommended by the manufacturer or installed contrary to instructions may cause an unsafe condition. The use of damaged components may cause an unsafe condition and void product warranty.
- Do not block light emanating from product in whole or part, as this may cause an unsafe condition.
- Never operate the fixture with missing or damaged lens. Lens must be cleaned on regular basis.
- Entire fixture may become extremely hot. Do not touch hot lens or fixture body.
- Replace LED assembly only with correct wattage and type of power supply appropriate for LED assembly.
- All gaskets, o-rings and sealing surfaces must be kept clean during installation and service; failure to do this may cause an unsafe condition and void product warranty.

IMPORTANT LISTINGS AND CERTIFICATIONS

- Suitable for wet locations • Suitable for recessed in ground locations

Proper soil preparation is recommended before installation. See the DIG-IT guide at www.bklighting.com/collaterals/install/digit.pdf for more information.

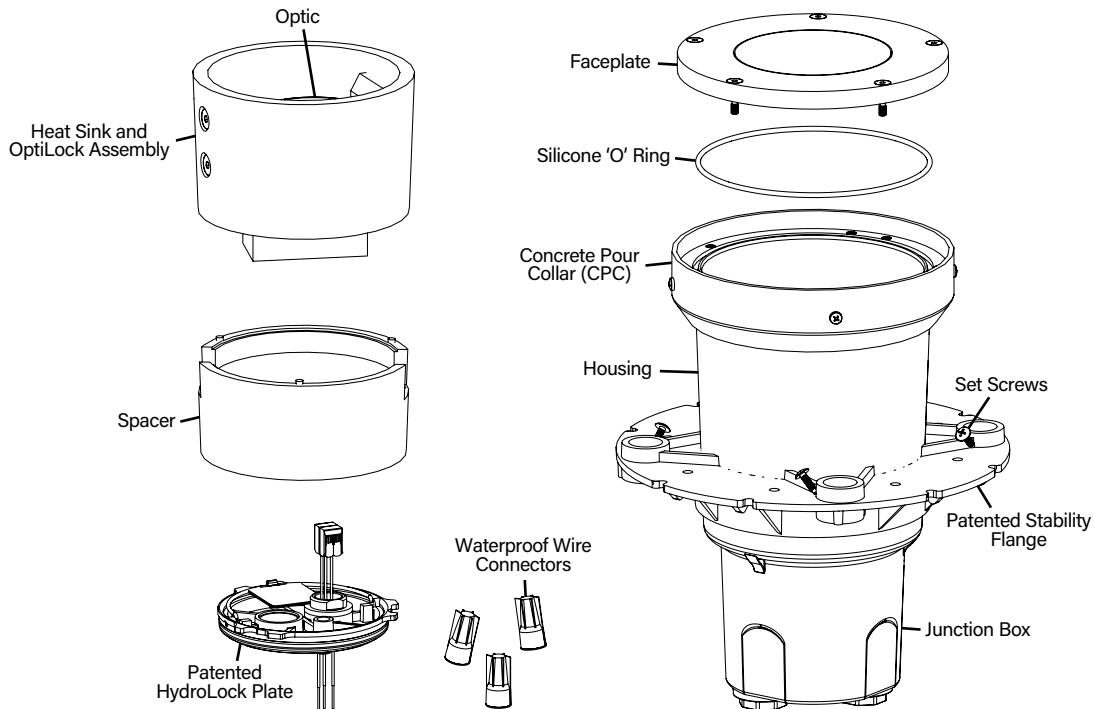

IMPORTANT SAFETY INFORMATION - READ, FOLLOW, AND SAVE THESE INSTALLATION INSTRUCTIONS

B-K LIGHTING

40429 Brickyard Drive • Madera, CA 93636 • USA
559.438.5800 • FAX 559.438.5900
www.bklighting.com • info@bklighting.com

RELEASE DATE
09/25/2023

REFERENCE NUMBER
INS-2405-00

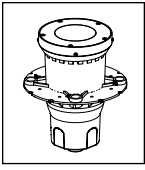

Standard Installation

Soil Prep

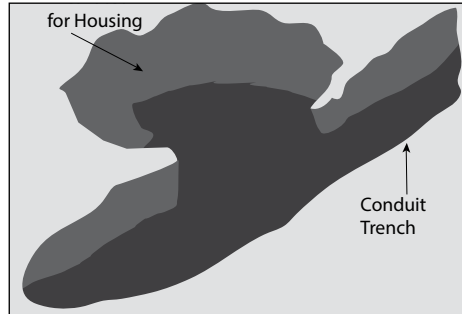
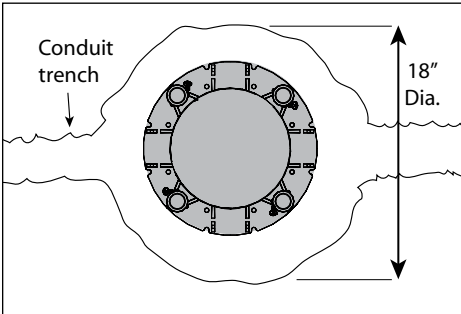

1. Determine Soil Type by referencing DIG-IT Guide.
2. Dig hole 18" wide and 18" deep.
3. Prep soil according to DIG-IT Guide.

SCAN WITH SMART DEVICE OR CLICK THE BAR CODE FOR ONLINE DIG-IT GUIDE

Housing Installation

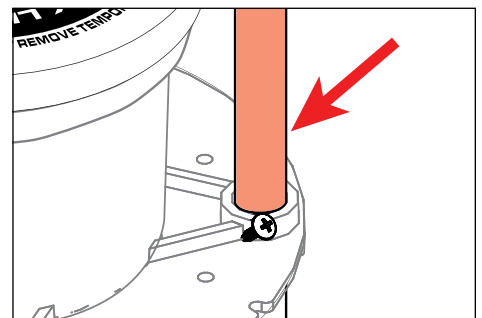
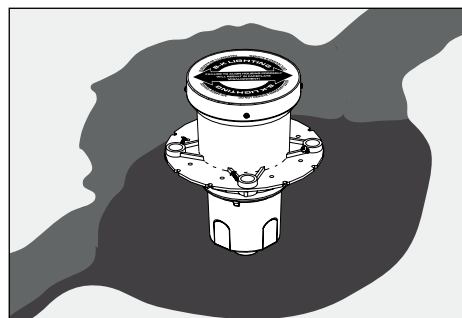
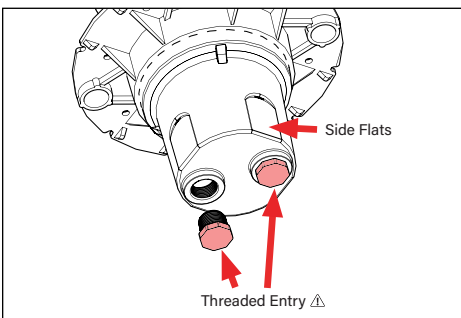

1. Connect branch conduit connectors (not included) to the junction box using either the threaded conduit entries on the bottom of the junction box or through holes drilled into the sides of the junction box.
2. Place housing in hole. Align junction box in the path of the conduit trench.
3. Insert four (4) pieces of 1/2" PVC/EMT conduit through the stability flange. Hammer into substrate until secure.

⚠ Remove 3/4" plug to install conduit connector. Any unused conduit entries should remain plugged.

⚠ Leave sufficient clearance to elevate housing to finished grade.

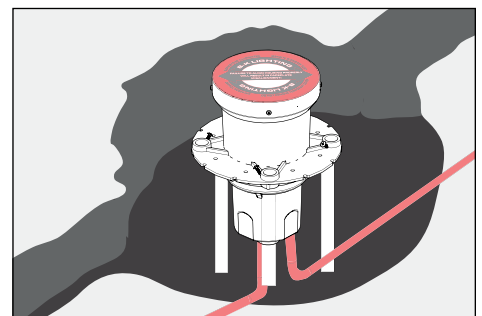
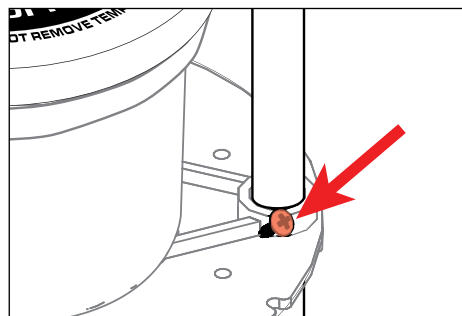
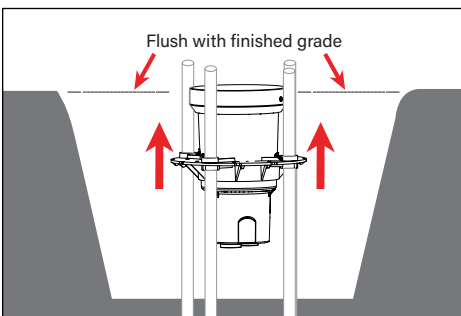

4. Raise housing on PVC/EMT so housing is flush with finished grade. Use a level to aid in housing installation.
5. When housing is level, tighten screws on stability flange to secure housing to PVC/EMT. Remove excess PVC/EMT as needed.
6. Pull primary branch circuit wiring into junction box.

**IMPORTANT SAFETY INFORMATION LISTED ON REVERSE
READ, FOLLOW, AND SAVE ALL SAFETY AND INSTALLATION INSTRUCTIONS**



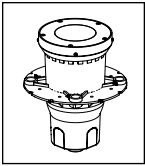

Standard Installation

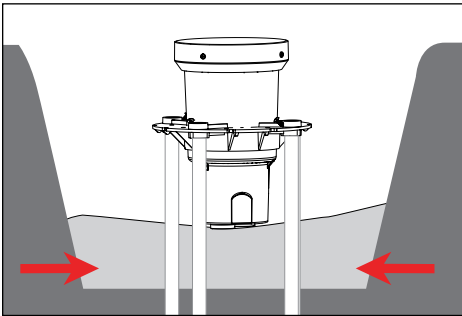

7. Per DIG-IT Guide, backfill hole based off of determined soil type.

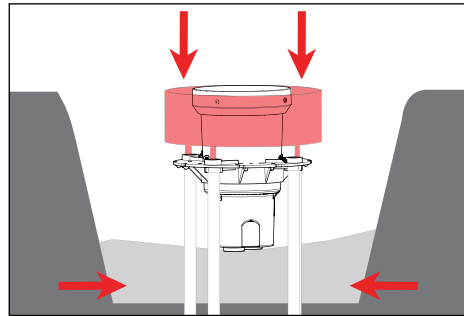

OPTIONAL GROUT MASK INSTALLATION (IF ORDERED)

7. Fill partway, then place grout mask around housing, centered at faceplate. Insert stakes through stability flange. Top of grout mask should be flush with grade.

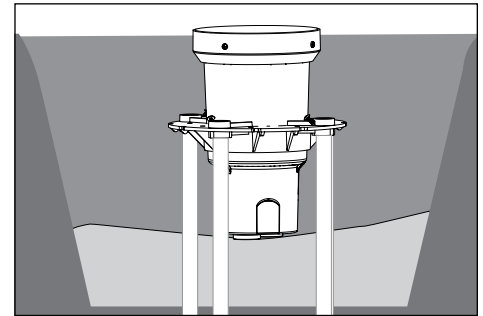

8. **For soil installation:** Fill and tamp soil to the appropriate height leaving room for sod, pavers, etc. to be level with the top of the temporary cover.

⚠ Soil installation is not drive-over rated.

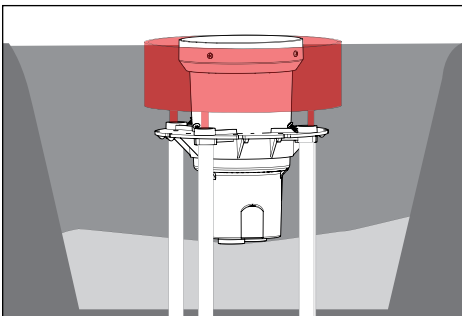

OPTIONAL GROUT MASK INSTALLATION (IF ORDERED)

8. **For soil installation:** Fill and tamp soil to the appropriate height leaving room for sod, pavers, etc. to be level with the top of the temporary cover.

⚠ Soil installation is not drive-over rated.

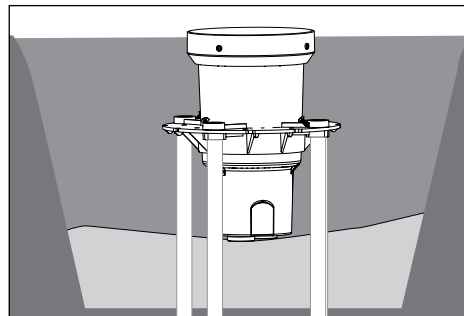

9. **For concrete installation:** Fill the hole around the fixture housing to 7" below the finished grade with clean fill dirt and tamp carefully to prevent settling of fixture. Pour concrete and finish as required flush with the top surface of the temporary cover.

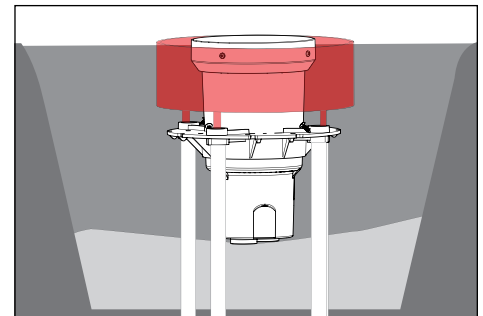

OPTIONAL GROUT MASK INSTALLATION (IF ORDERED)

9. **For concrete installation:** Fill the hole around the fixture housing to 12" below the finished grade with clean fill dirt and tamp carefully to prevent settling of fixture. Pour concrete and finish as required flush with the top surface of the grout mask.

**IMPORTANT SAFETY INFORMATION LISTED ON REVERSE
READ, FOLLOW, AND SAVE ALL SAFETY AND INSTALLATION INSTRUCTIONS**



B-K LIGHTING

40429 Brickyard Drive • Madera, CA 93636 • USA
559.438.5800 • FAX 559.438.5900
www.bklighting.com • info@bklighting.com

RELEASE DATE
09/25/2023

REFERENCE NUMBER
INS-2405-00

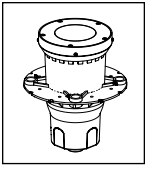

Standard Installation

HP2
INTEGRAL - LED

Installation

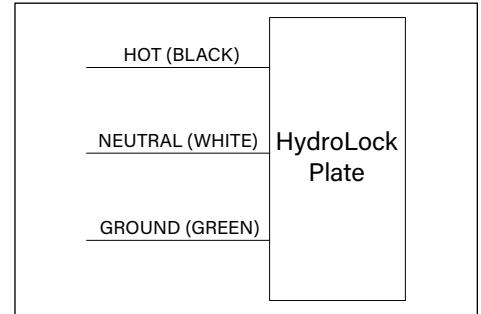
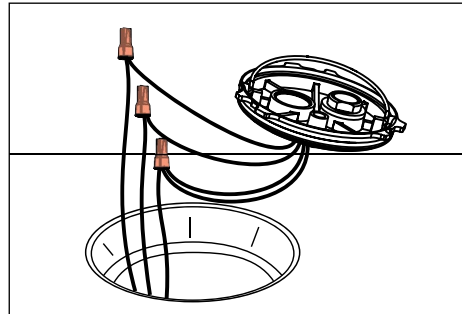

1. Remove temporary cover.
2. Pull primary branch circuit to installed housings.

3. Make connections using waterproof wire nuts (included) to leads on the bottom of Patented HydroLock Barrier Plate Assembly. **See wiring diagram.**

WIRING DIAGRAM

- Non-Dimming
- INC Dimming
- ELV Dimming

⚠ All line voltage connections must be made in compliance with the National Electrical Code. Failure to do so will void warranty.

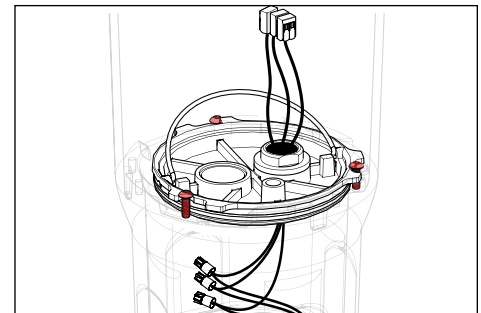
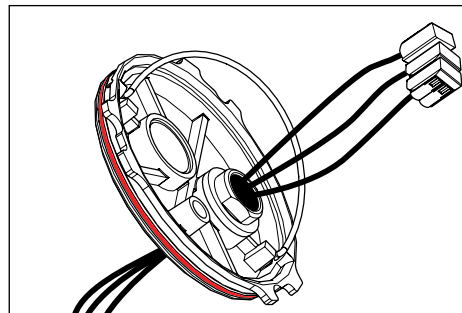
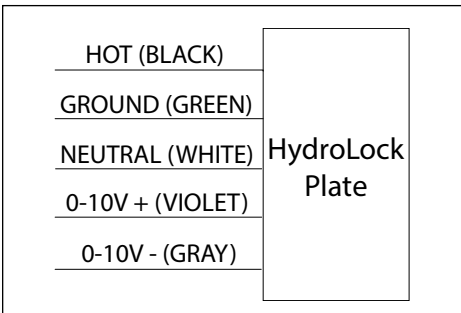

WIRING DIAGRAM

- 0-10V Dimming

⚠ All line voltage connections must be made in compliance with the National Electrical Code. Failure to do so will void warranty.

4. Wipe inside of housing where HydroLock plate will sit clean of debris before inserting patented HydroLock plate on to junction box. Align HydroLock plate with pins in housing and seat it firmly in place.

5. Turn HydroLock Barrier Plate clockwise 1/4" to lock.
- ⚠ Patented HydroLock Barrier Plate must be completely seated to ensure proper seal or water may intrude. This step must be done as stated or you will void your warranty.**

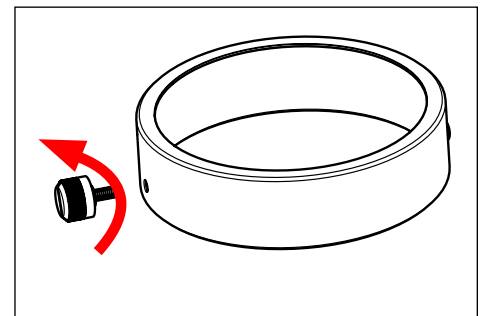
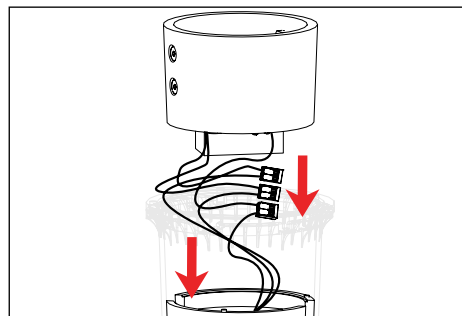
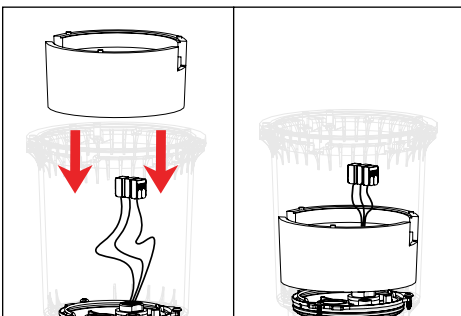

6. Install spacer into HP2 housing. Pull Hydrolock plate wiring through spacer and lower spacer into the bottom of HP2 housing.

Do not force spacer into HP2 housing.

7. Make connections using wago connectors to Optilock assembly and Hyrdolock plate wiring. To connect, lift the lever on the wago, insert the conductor into opening, then snap the lever back down. **Refer to Wiring diagram.**

8. HP2 Accy Holder Installation/Removal

⚠ For Optional Accessory Holder: Loosen the thumbscrew and then tilt the Accessory Holder up off the reflector so the second screw can clear the edge of the reflector.

**IMPORTANT SAFETY INFORMATION LISTED ON REVERSE
READ, FOLLOW, AND SAVE ALL SAFETY AND INSTALLATION INSTRUCTIONS**



B-K LIGHTING

40429 Brickyard Drive • Madera, CA 93636 • USA
559.438.5800 • FAX 559.438.5900
www.bklighting.com • info@bklighting.com

RELEASE DATE
09/25/2023

REFERENCE NUMBER
INS-2405-00

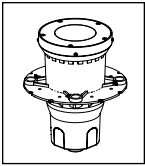

Standard Installation

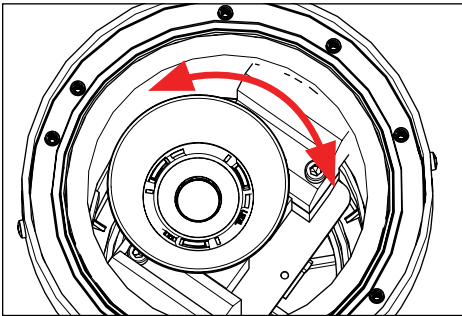

9. To aim OptiLock horizontally: lift OptiLock from resting position, and rotate to desired angle. Set down on spacer.

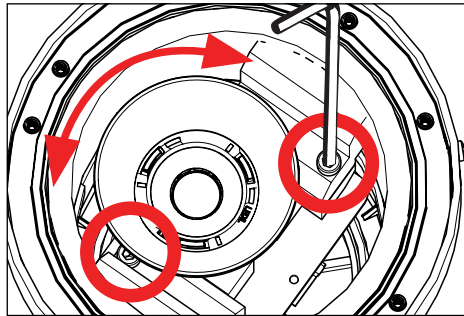

10. To aim OptiLock vertically: loosen two (2) 1/4-20 screws using a 3/16" allen wrench. Tilt swivel arm with LED and optic in desired aiming direction. Tighten two (2) 1/4-20 screws with a 3/16" allen wrench to secure position.

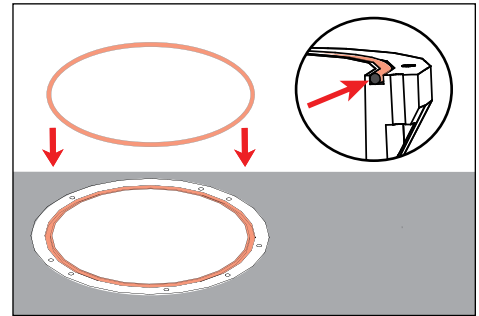

11. Remove any dirt or debris in o-ring groove near top of housing. Place o-ring inside of groove.

⚠ Failure to remove debris from groove will cause fixture to fail and void product warranty.

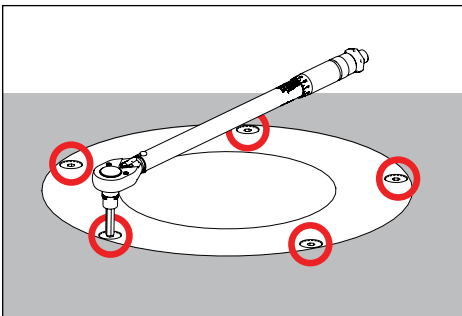

12. Install faceplate using a 1/8" allen wrench and hand-tighten the faceplate screws in a star pattern to 30 in-lbs. min.

⚠ Do not use a power tool to install screws. Do not exceed 40 in-lbs.

**IMPORTANT SAFETY INFORMATION LISTED ON REVERSE
READ, FOLLOW, AND SAVE ALL SAFETY AND INSTALLATION INSTRUCTIONS**



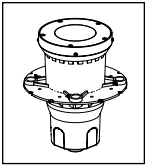

HP2/CO2 LED (31W-52W)

Standard Adjustment



Flammable



Warning



High Voltage



Hot Surface

TOOLS NEEDED:

- 1/8" 3/16" & 0.050" Allen Wrench
- Phillips Screwdriver
- Small Pick Tool
- Torque Wrench

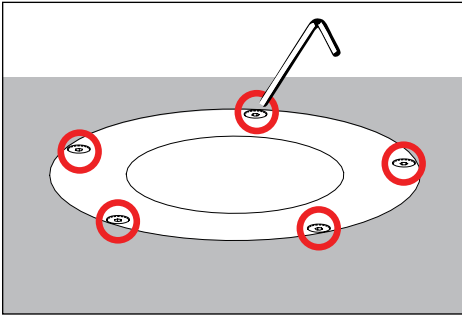

1. Remove faceplate using a 1/8" allen wrench. Remove optional accessory holder (if applicable).

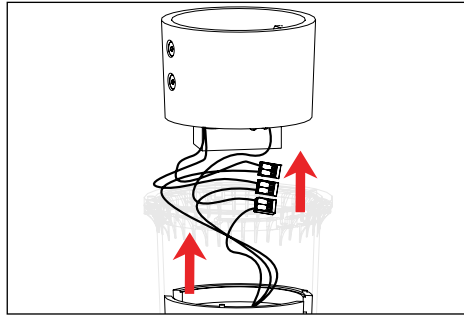

2. Turn, then lift OptiLock from housing. Disconnect OptiLock assembly from driver assembly wago connectors.

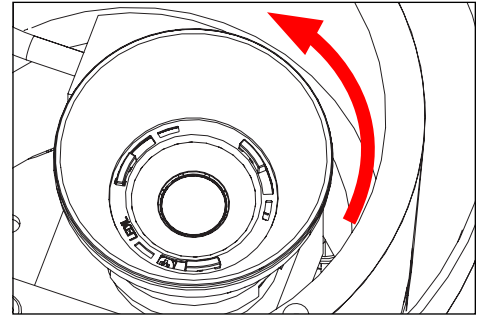

3. Remove optic by turning to the left to unlock optic from optic holder tabs, and lift up.

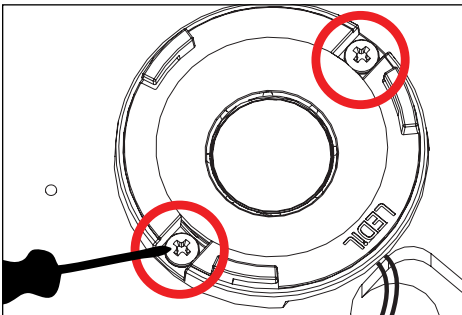

4. Use small Phillips screwdriver to remove two (2) #4-40 fasteners on optic holder, then remove optic holder to expose LED module.

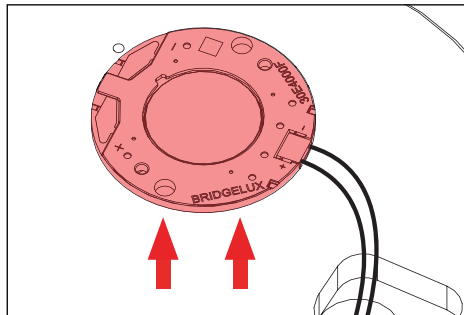

5. Carefully remove LED module from heatsink.

⚠ Do not pull on connector or wiring. Handle with care.

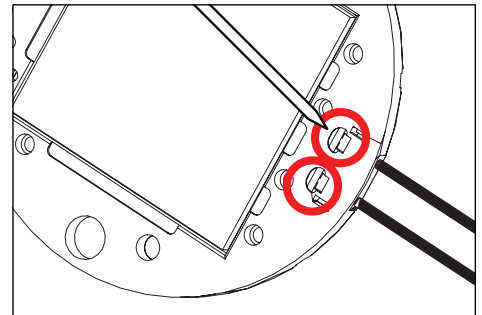

6. Use small pick tool to push connector off LED board through two small slots behind connector. Once loose, lift connector upwards and off board.

⚠ Do not pull on connector or wiring. Handle with care.

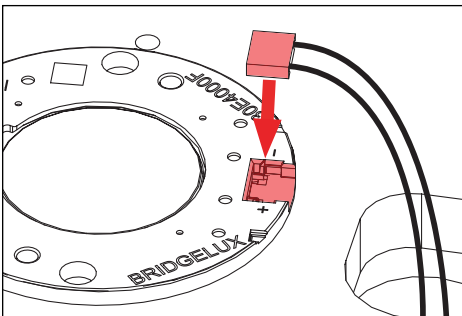

7. Place new LED module onto heatsink. Press connector straight downwards into slot on module to snap into place.

⚠ Connector will only fit in one direction.

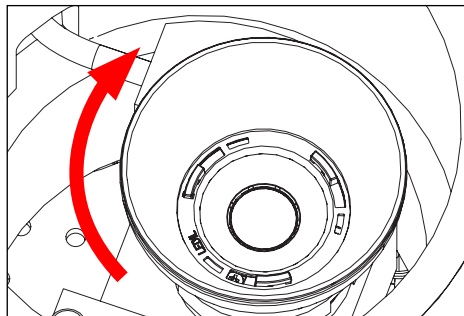

8. Reverse install optic holder, and then optic.

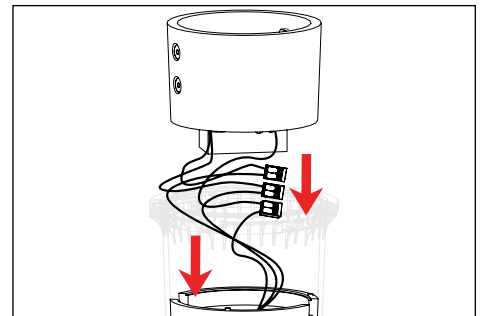

9. Attach OptiLock assembly to installed driver assembly with wago connectors. Place OptiLock assembly in housing, resting the OptiLock on the spacer. Gravity will hold OptiLock in place.

IMPORTANT SAFETY INFORMATION - READ, FOLLOW, AND SAVE THESE INSTALLATION INSTRUCTIONS

B-K LIGHTING

40429 Brickyard Drive • Madera, CA 93636 • USA
559.438.5800 • FAX 559.438.5900
www.bklighting.com • info@bklighting.com

RELEASE DATE
09/25/2023

REFERENCE NUMBER
INS-2405-02

THIS DOCUMENT CONTAINS PROPRIETARY INFORMATION OF B-K LIGHTING, INC. AND ITS RECEIPT OR POSSESSION DOES NOT CONVEY ANY RIGHTS TO REPRODUCE, DISCLOSE ITS CONTENTS, OR TO MANUFACTURE, USE OR SELL ANYTHING IT MAY DESCRIBE. REPRODUCTION, DISCLOSURE OR USE WITHOUT SPECIFIC WRITTEN AUTHORIZATION OF B-K LIGHTING, INC. IS STRICTLY FORBIDDEN.

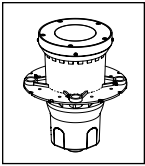

Standard Adjustment

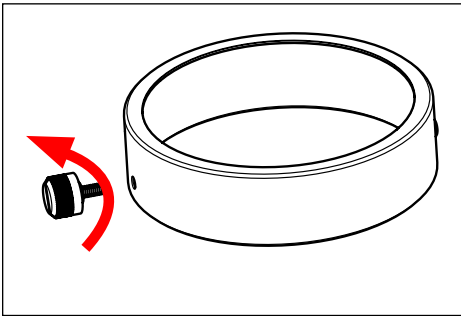

10. HP2 Accy Holder Installation/Removal

⚠ For Optional Accessory Holder: Loosen the thumbscrew and then tilt the Accessory Holder up off the reflector so the second screw can clear the edge of the reflector.

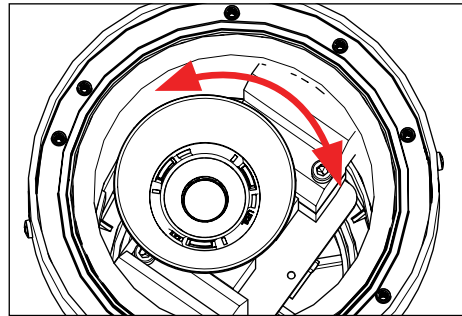

11. To aim OptiLock horizontally: lift OptiLock from resting position, and rotate to desired angle. Set down on spacer. Gravity will hold OptiLock in place.

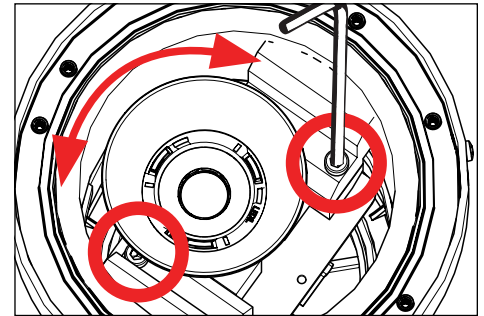

12. To aim OptiLock vertically: loosen two (2) 1/4-20 screws using a 3/16" allen wrench. Tilt swivel arm with LED and optic in desired aiming direction. Tighten two (2) 1/4-20 screws with a 3/16" allen wrench to secure position.

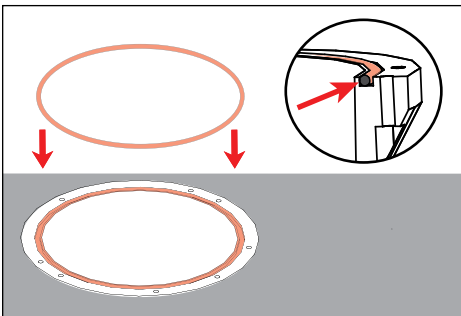

13. Remove any dirt or debris in o-ring groove near top of housing. Place o-ring inside of groove.

⚠ Failure to remove debris from groove will cause fixture to fail and void product warranty.

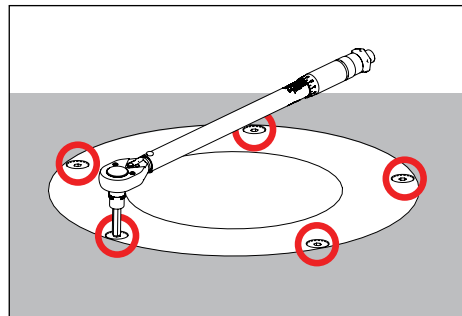

14. Install faceplate using a 1/8" allen wrench and hand-tighten the faceplate screws in a star pattern to 30 in-lbs. min.

⚠ Do not use a power tool to install screws. Do not exceed 40 in-lbs.

**IMPORTANT SAFETY INFORMATION LISTED ON REVERSE
READ, FOLLOW, AND SAVE ALL SAFETY AND INSTALLATION INSTRUCTIONS**



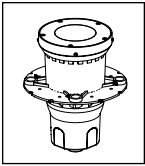

HP2/CO2 LED (18W-29W)

Standard Adjustment



Flammable



Warning





High Voltage



Hot Surface

TOOLS NEEDED:

-  1/8" 3/16" & 0.050" Allen Wrench
-  Phillips Screwdriver
-  Torque Wrench

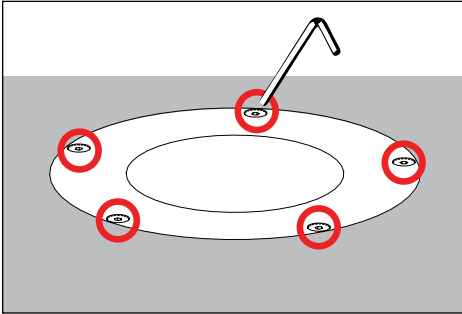

1. Remove faceplate using a 1/8" allen wrench. Remove optional accessory holder (if applicable).

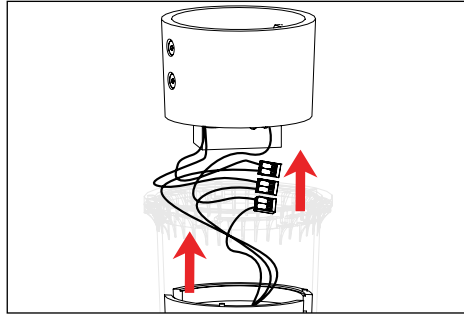

2. Turn, then lift OptiLock from housing. Disconnect OptiLock assembly from driver assembly using quick disconnect.

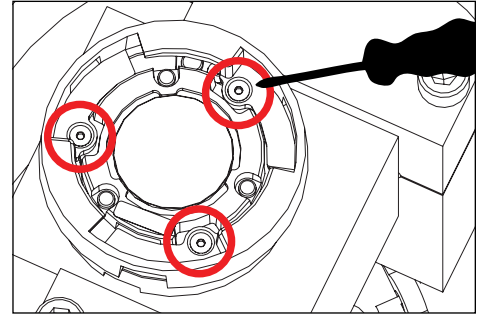

3. Remove optic by turning to the left and lifting up. Remove the optic holder from the LED board by loosening three (3) optic holder fasteners using a 0.050" allen wrench.

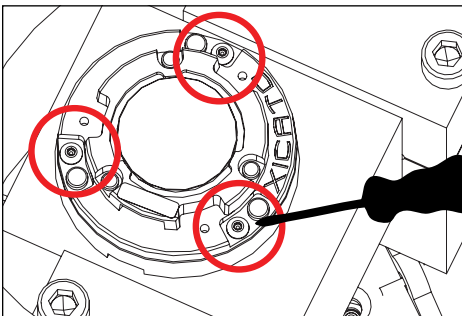

4. Use a 0.050" allen wrench to loosen three (3) #2-56 screws on LED component. Reverse install new LED component. Ensure LED component is firmly seated on heatsink. **LED component can only fit in one direction.**

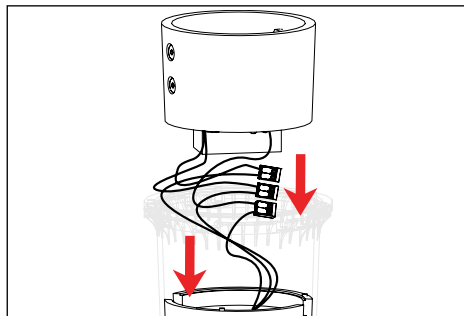

6. Attach OptiLock assembly to installed driver assembly with quick disconnect. Place OptiLock assembly in housing, resting the OptiLock on the pins provided inside the housing. Gravity will hold OptiLock in place.

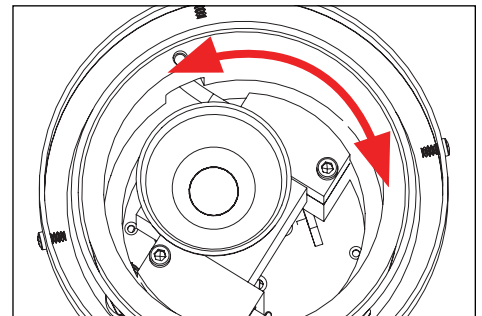

7. To aim OptiLock horizontally: lift OptiLock from resting position, and rotate to desired angle. Set down on pins provided in housing. Gravity will hold OptiLock in place.

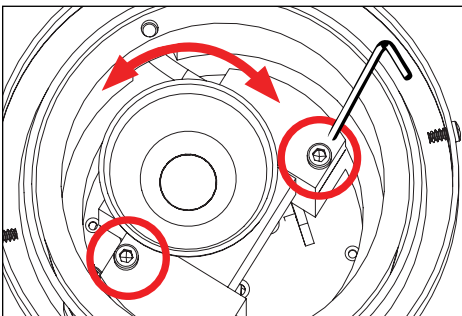

5. Install optic holder with three (3) optic holder fasteners using a 0.050" allen wrench. Reverse install optic.

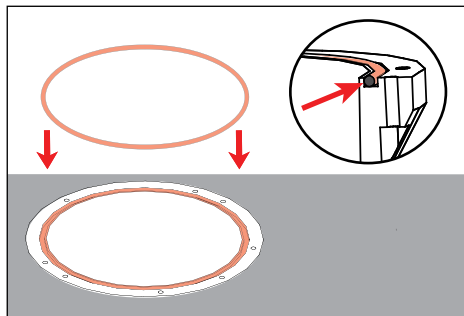

9. Remove any dirt or debris in o-ring groove near top of housing. Place o-ring inside of groove.

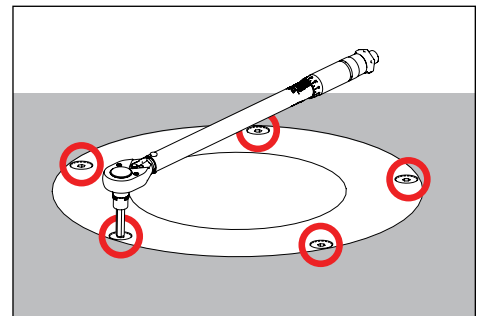

8. To aim OptiLock vertically: loosen two (2) 1/4-20 screws using a 3/16" allen wrench. Tilt swivel arm with LED and optic in desired aiming direction. Tighten two (2) 1/4-20 screws with a 3/16" allen wrench to secure position.

⚠ Failure to remove debris from groove will cause fixture to fail and void product warranty.

⚠ Do not use a power tool to install screws. Do not exceed 40 in-lbs.

IMPORTANT SAFETY INFORMATION - READ, FOLLOW, AND SAVE THESE INSTALLATION INSTRUCTIONS

B-K LIGHTING

40429 Brickyard Drive • Madera, CA 93636 • USA
559.438.5800 • FAX 559.438.5900
www.bklighting.com • info@bklighting.com



RELEASE DATE
09/25/2023

REFERENCE NUMBER
INS-2405-01

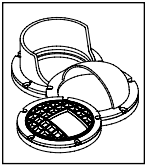
THIS DOCUMENT CONTAINS PROPRIETARY INFORMATION OF B-K LIGHTING, INC. AND ITS RECEIPT OR POSSESSION DOES NOT CONVEY ANY RIGHTS TO REPRODUCE, DISCLOSE ITS CONTENTS, OR TO MANUFACTURE, USE OR SELL ANYTHING IT MAY DESCRIBE. REPRODUCTION, DISCLOSURE OR USE WITHOUT SPECIFIC WRITTEN AUTHORIZATION OF B-K LIGHTING, INC. IS STRICTLY FORBIDDEN.



Accessories Installation Instructions

TOOLS NEEDED:	 1/8" & 7/64" Allen Wrench
	 Torque Wrench



Warning



Hot Surface

INSTRUCTIONS PERTAINING TO A RISK OF FIRE, OR INJURY TO PERSONS IMPORTANT SAFETY INSTRUCTIONS

Lighted fixture is HOT!
WARNING - To reduce the risk of FIRE OR INJURY TO PERSONS:
 Turn off/unplug and allow to cool before replacing lamp/LED. Fixture gets HOT quickly! Contact only switch/plug when turning on. Do not touch hot lens, guard, or enclosure. Keep fixture away from materials that may burn. Do not operate the luminaire fitting with a missing or damaged shield. Do not touch the source at any time. Use a soft cloth or gloves. Oil from skin may cause damage.

SAVE THESE INSTRUCTIONS

IMPORTANT SAFETY INFORMATION - READ, FOLLOW, AND SAVE ALL SAFETY AND INSTALLATION INSTRUCTIONS

- Product must be installed by a qualified person in a manner consistent with its intended use and in compliance with the National Electrical Code, Canadian Electrical Code, and all Local and Provincial Codes.
- Follow product label information and instructions.
- Qualified Personnel with appropriate personal protective equipment must perform all servicing of this product.
- Before wiring to power supply and during servicing, turn off and lock out power at fuse or circuit breaker before service.
- The use of accessory equipment not recommended by the manufacturer or installed contrary to instructions may cause an unsafe condition. The use of damaged components may cause an unsafe condition and void product warranty.
- Do not block light emanating from product in whole or part, as this may cause an unsafe condition.
- Never operate the fixture with missing or damaged lens. Lens must be cleaned on regular basis.
- Entire fixture may become extremely hot. Do not touch hot lens or fixture body.
- Replace LED assembly only with correct wattage and type of power supply appropriate for LED assembly.
- All gaskets, o-rings and sealing surfaces must be kept clean during installation and service; failure to do this may cause an unsafe condition and void product warranty.

IMPORTANT LISTINGS AND CERTIFICATIONS

• Suitable for wet locations • Additionally suitable for mounting within 4 ft. of the ground

Proper soil preparation is recommended before installation. See the DIG-IT guide at www.bklighting.com/collaterals/install/digit.pdf for more information.

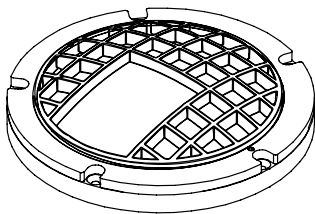

Rock Guard with Optical Opening

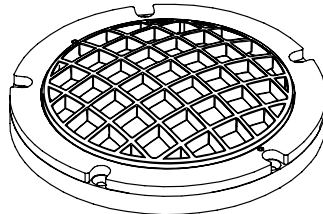

Rock Guard

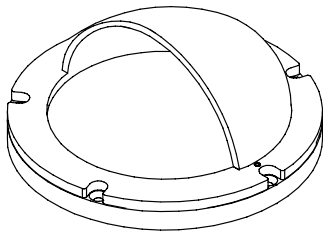

Half Dome B

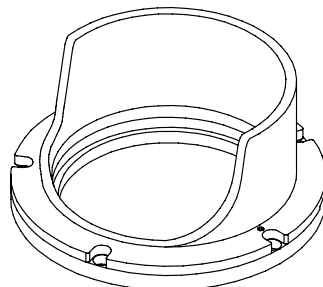

Glare Shield B

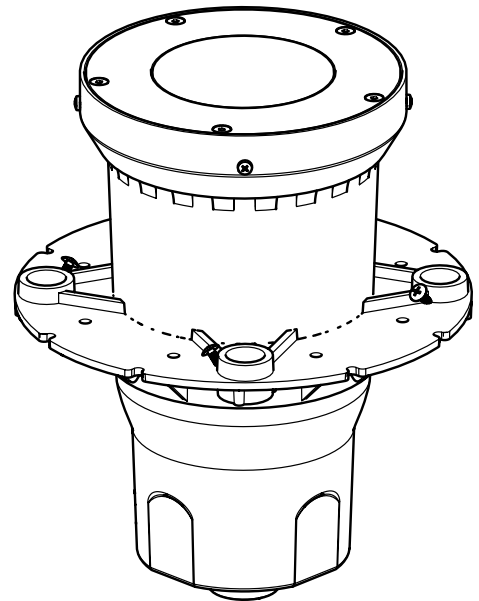

IMPORTANT SAFETY INFORMATION - READ, FOLLOW, AND SAVE THESE INSTALLATION INSTRUCTIONS

B-K LIGHTING	40429 Brickyard Drive • Madera, CA 93636 • USA 559.438.5800 • FAX 559.438.5900 www.bklighting.com • info@bklighting.com	RELEASE DATE 09/25/2023	REFERENCE NUMBER INS-2882-00
	THIS DOCUMENT CONTAINS PROPRIETARY INFORMATION OF B-K LIGHTING, INC. AND ITS RECEIPT OR POSSESSION DOES NOT CONVEY ANY RIGHTS TO REPRODUCE, DISCLOSE ITS CONTENTS, OR TO MANUFACTURE, USE OR SELL ANYTHING IT MAY DESCRIBE. REPRODUCTION, DISCLOSURE OR USE WITHOUT SPECIFIC WRITTEN AUTHORIZATION OF B-K LIGHTING, INC. IS STRICTLY FORBIDDEN.		

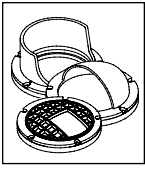

Accessories Installation Instructions

Faceplate Accessories

Instructions Apply To...

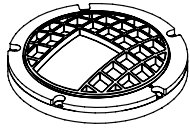

Rock Guard with Optical Opening

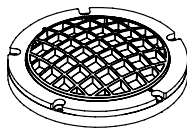

Rock Guard

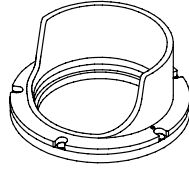

Glare Shield B

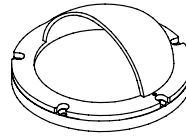

Half Dome B

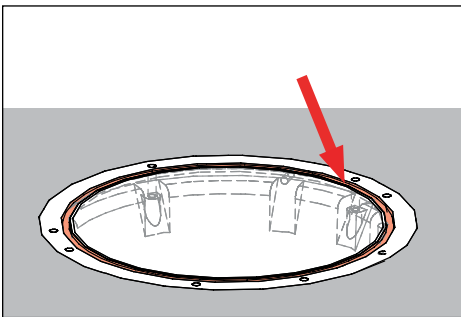

1. Before installation of faceplate, clean o-ring groove and collar of debris for a proper seal.

⚠ Failure to remove debris from groove will cause fixture to fail and void product warranty.

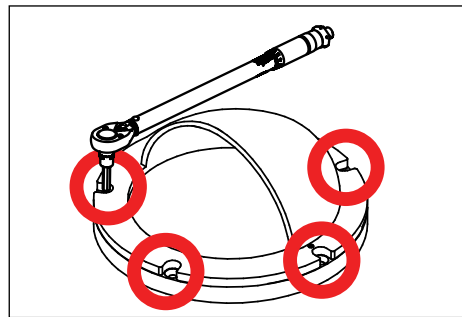

2. Install faceplate using a 1/8" allen wrench and hand-tighten the five (5) #10-24 faceplate screws in a star pattern to 30 in-lbs. min.

⚠ Do not use a power tool to install screws. Do not exceed 40 in-lbs.

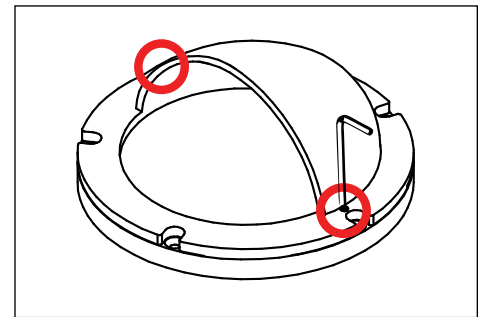

3. Using a 7/64" allen wrench, loosen the two (2) #6-32 set screws on the faceplate to allow accessory to rotate freely.

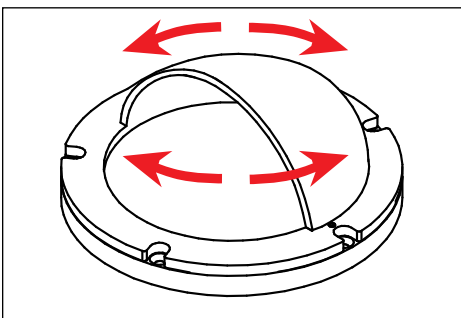

4. Accessory can rotate 360° independently of faceplate.

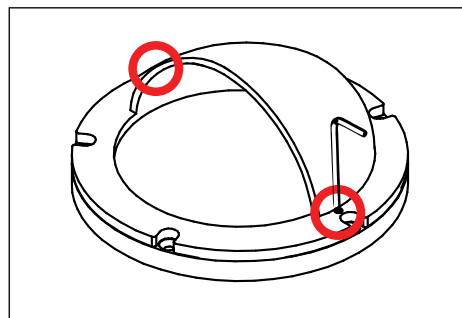

5. When set in final position, tighten two (2) #6-32 screws using a 7/64" allen wrench.

**IMPORTANT SAFETY INFORMATION LISTED ON REVERSE
READ, FOLLOW, AND SAVE ALL SAFETY AND INSTALLATION INSTRUCTIONS**



B-K LIGHTING

40429 Brickyard Drive • Madera, CA 93636 • USA
559.438.5800 • FAX 559.438.5900
www.bklighting.com • info@bklighting.com

RELEASE DATE
09/25/2023

REFERENCE NUMBER
INS-2882-00