

BKSSL Invisi™ Mount Installation

MINI-MICRO™ iLUME™



Warning



High Voltage



Flammable



Hot Surface

TOOLS NEEDED:



5/64" allen wrench



Wire connectors



1 1/2" drill bit and drill

IMPORTANT SAFETY INFORMATION - READ, FOLLOW, AND SAVE ALL SAFETY AND INSTALLATION INSTRUCTIONS

- Product must be installed by a qualified person in a manner consistent with its intended use and in compliance with the National Electrical Code, Canadian Electrical Code, and all Local and Provincial Codes.
- The use of accessory equipment not recommended by the manufacturer or installed contrary to instructions may cause an unsafe condition. The use of damaged components may cause an unsafe condition and void product warranty.
- Entire fixture may become extremely hot. Do not touch hot lens or fixture body. Do not touch the lamp at any time. Use a clean, dry, soft cloth to handle the lamp. Oil from skin may damage the lamp and cause it to rupture.
- Follow product label information and instructions.
- Do not block light emanating from product in whole or part, as this may cause an unsafe condition.
- Replace lamp only with correct wattage and type of lamp marked on fixture label.
- Qualified Personnel must perform all servicing or relamping of this product.
- Never operate the fixture with missing or damaged lens. Lens must be cleaned on regular basis.
- All gaskets, o-rings and sealing surfaces must be kept clean during installation and service; failure to do this may cause an unsafe condition and void product warranty.
- Before wiring to power supply and during servicing or relamping, turn off power at fuse or circuit breaker before service.
- Lighted lamp gets hot very quickly. Allow it to cool before replacing lamp.

Please refer to the low voltage design guide at www.bklighting.com/lvguide before installation for proper wire selection.

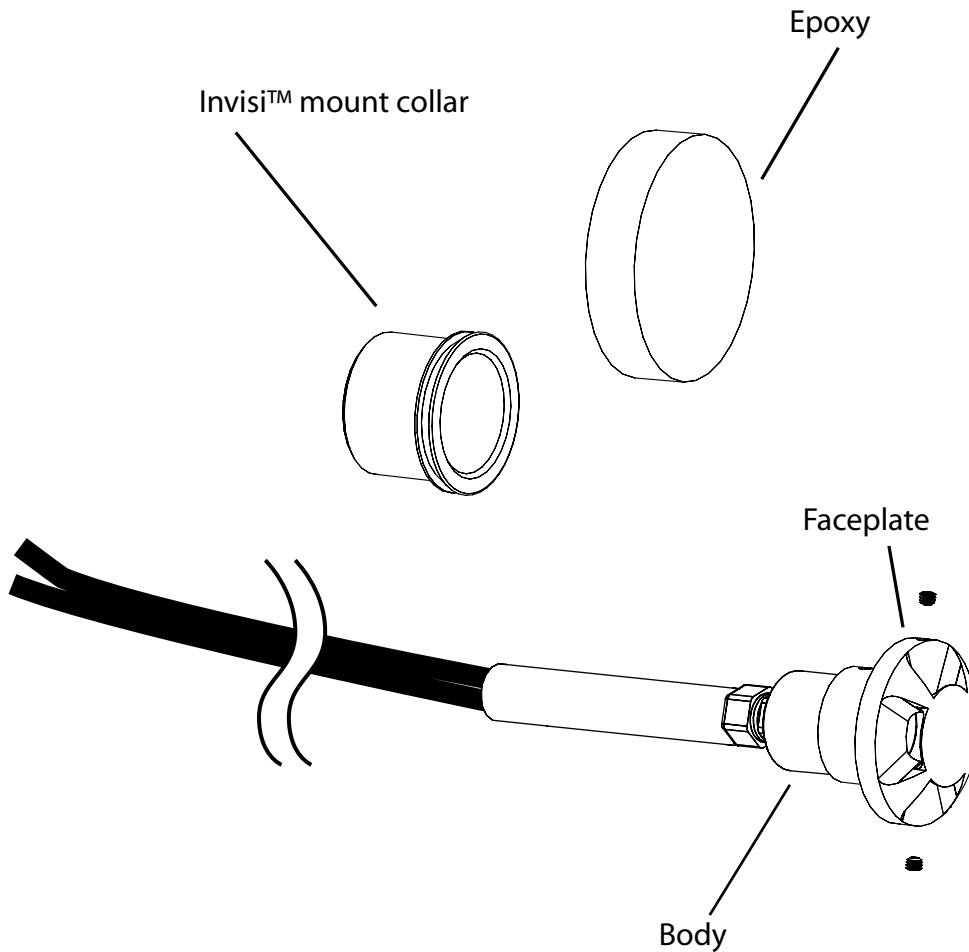

B-K LIGHTING

40429 Brickyard Drive • Madera, CA 93636 • USA
559.438.5800 • FAX 559.438.5900
www.bklighting.com • info@bklighting.com

SUBMITTAL DATE
7-30-09

REFERENCE NUMBER
INS-001080.3

THIS DOCUMENT CONTAINS PROPRIETARY INFORMATION OF B-K LIGHTING, INC. AND ITS RECEIPT OR POSSESSION DOES NOT CONVEY ANY RIGHTS TO REPRODUCE, DISCLOSE ITS CONTENTS, OR TO MANUFACTURE, USE OR SELL ANYTHING IT MAY DESCRIBE. REPRODUCTION, DISCLOSURE OR USE WITHOUT SPECIFIC WRITTEN AUTHORIZATION OF B-K LIGHTING, INC. IS STRICTLY FORBIDDEN.

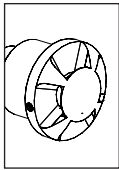

BKSSL Invisi™ Mount Installation

MINI-MICRO™ iLUME™

| | |
|----------|--|
| PROJECT: | |
| TYPE: | |

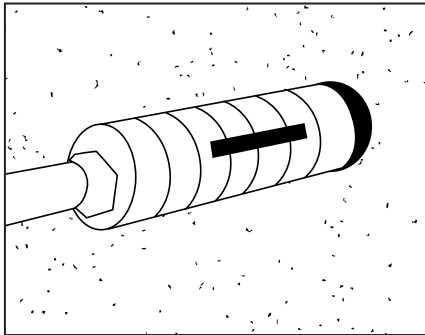

1. Drill 1-1/2" diameter hole, 3" deep minimum, for fixture.



2. Prepare epoxy according to instructions on packaging.

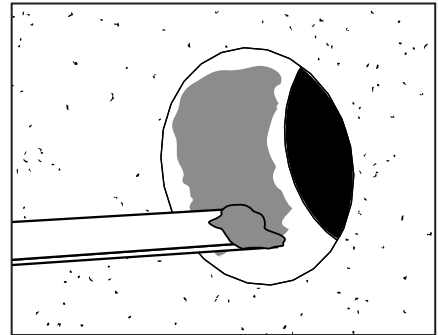

3. Use mixing stick to apply the epoxy to the interior of the 1-1/2" hole as shown.

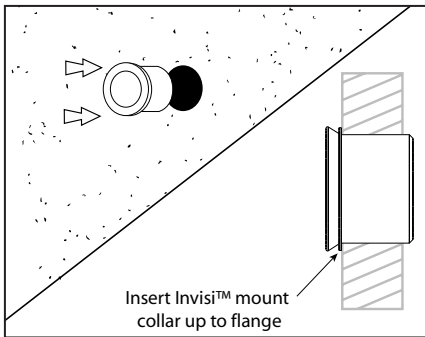

Insert Invisi™ mount collar up to flange

4. Fit Invisi™ mount collar into hole until flange comes in contact with building material. Wipe off any excess adhesive.

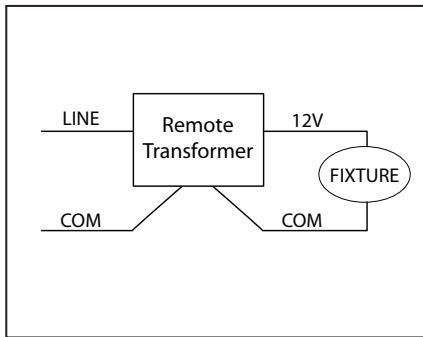

5. Pull wire through Invisi™ collar and make two water tight, low voltage connections using proper wire connectors (By Others). Insert wires and fixture back into hole.

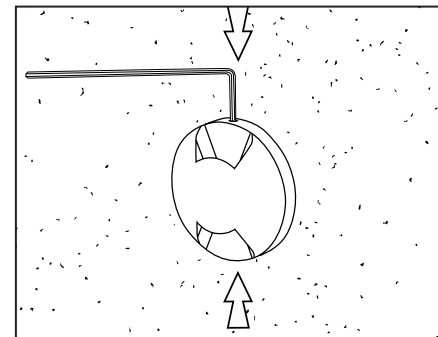

6. Loosen #8-32 set screws on the faceplate with 5/64" allen wrench. Align window(s) to surface to be illuminated. Tighten set screws.

⚠ Do not insert Invisi™ collar beyond flange!

⚠ NOTE: Leave sufficient wire length in hole for future service.

THIS PRODUCT IS AVAILABLE WITH A FACTORY INSTALLED LED.

LED INSTALLATION - IF REQUIRED

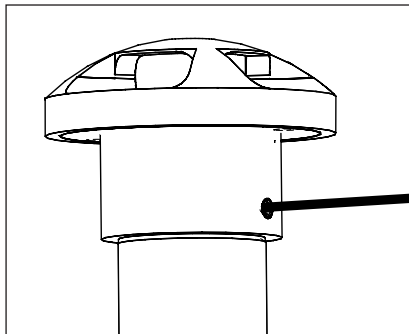

1. Loosen #8-32 set screw on faceplate assembly using a 5/64" allen wrench and remove.

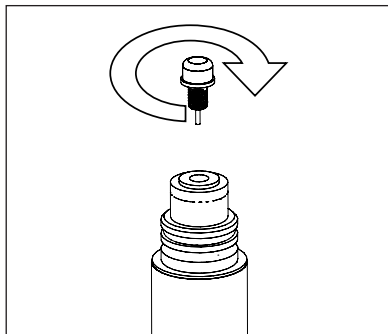

2. Install LED.

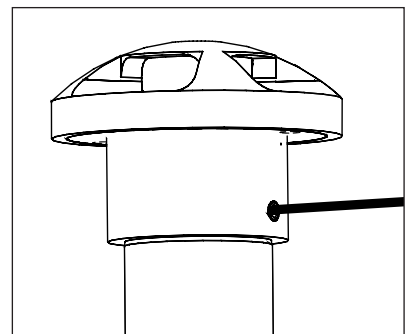

3. Replace faceplate assembly and tighten set screw.

**IMPORTANT SAFETY INFORMATION LISTED ON REVERSE
READ, FOLLOW, AND SAVE ALL SAFETY AND INSTALLATION INSTRUCTIONS**



ETL LISTED
CONFORMS TO ANSI/UL
STANDARD 1838 AND UL SUBJECT 8750
CERTIFIED TO CAN/CSA
STANDARD C22.2 NO. 9

B-K LIGHTING

40429 Brickyard Drive • Madera, CA 93636 • USA
559.438.5800 • FAX 559.438.5900
www.bklighting.com • info@bklighting.com

SUBMITTAL DATE
7-30-09

REFERENCE NUMBER
INS-001080.3